

FITTING INSTRUCTIONS

YAMAHA YZF-R3

120-015-270-005



IMPORTANT NOTES

KEY



NOTE!



CAUTION!



WARNING!



The front forks are a very important part of the motorcycle and will affect the safety and stability.



Read the instructions carefully and make sure you understand them before you proceed. If you have any queries please contact your dealer or nearest supplier of K-Tech Suspension immediately.



K-Tech Suspension Ltd. cannot be held responsible for any damage to vehicle, front fork, personal injury or property if the installation instructions are not followed exactly.



Please read this instruction manual before installing the cartridge kit.



This cartridge kit should only be installed by an authorised K-Tech Dealer.

- 1** This cartridge kit was designed and developed for a specific motorcycle model and should only be installed onto the recommended model in its original condition.

- 2** After this product has been installed you should take a low speed test ride to check stability of the vehicle has been maintained.

- 3** This product needs specialised tools to fit correctly and should only be fitted by a K-Tech dealer or a person with the correct tools and qualified in motorcycle suspension and trained to install the front fork cartridge kits to ensure the performance of this product.

- 4** When Fitting the kit, fit only one leg at a time to avoid confusion. Always fit the compression cartridge into the left hand leg and the rebound into the right.

- 5** Remove the front forks from the motorcycle using the manufacturer's workshop manual.



SECTION B

1

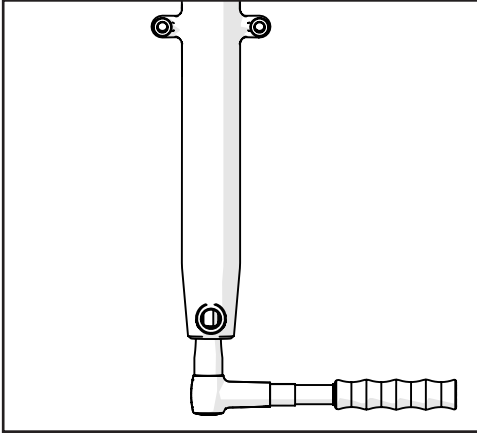

Remove standard cartridge by unscrewing the bolt in the bottom of the outer tube.

2

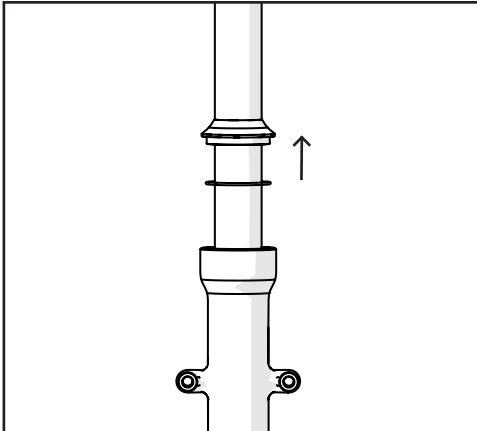

Remove Dust Seal and C-Clip.

4

3

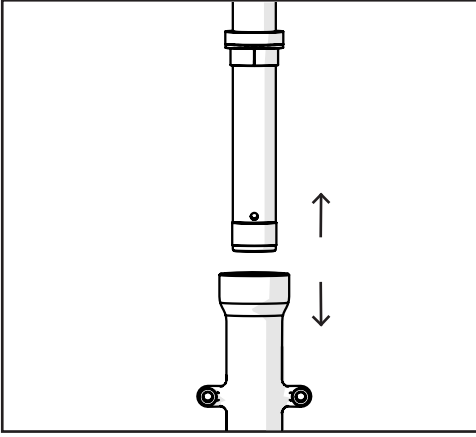

Remove the inner tube along with seals and bushes.

4

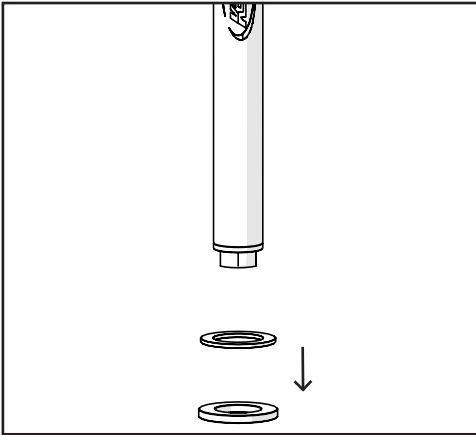

Remove the bump rubber and the washer from the bottom of the K-Tech cartridge.

5

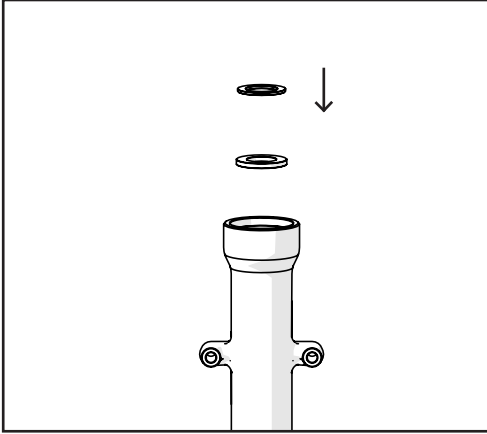

Install the bump rubber and the washer into the bottom of the outer tube. Install the bump rubber first making sure they seat correctly at the bottom of the tube.

6

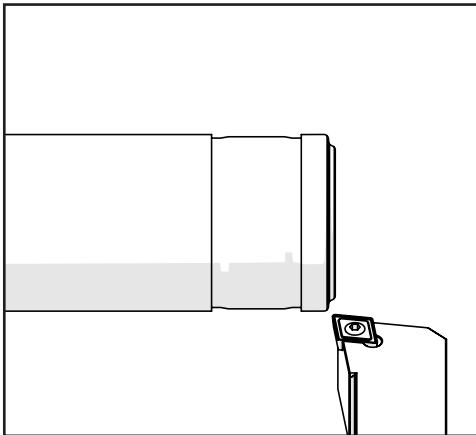

Remove the hydraulic lock from the inner tube by machining the swage off until it sits flush to the tube using a lathe. Then remove the internals and clean tube.

6

7

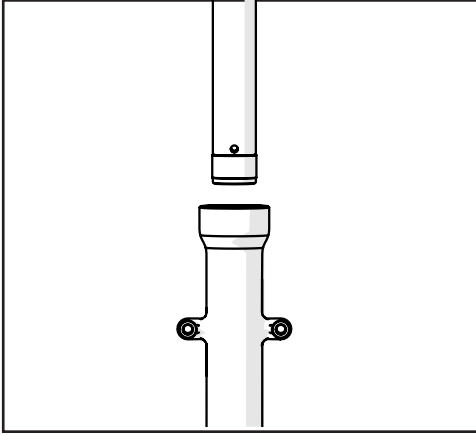

Install the Slide Bush onto the inner tube and lower into the outer tube.

8

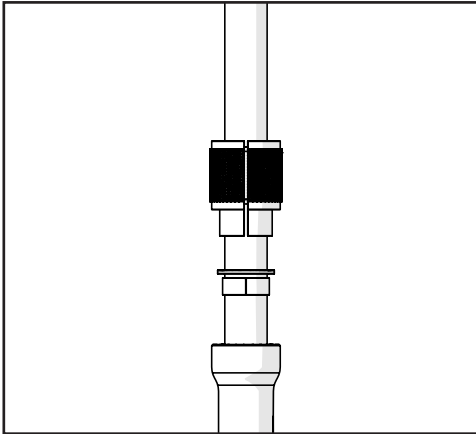

Install the slide bush and the washer using the seal driver.



If bush is worn or damaged replace with a new one.

9

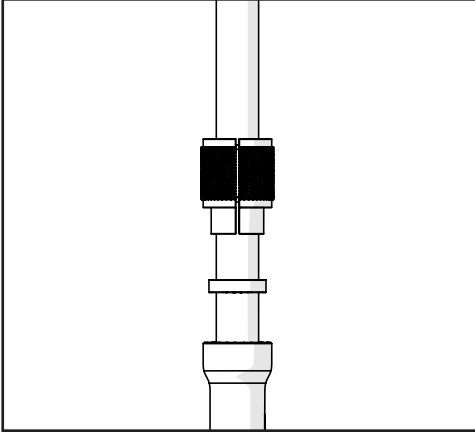

Grease seal before installing.

Install the oil seal using the seal driver. Making sure C-Clip groove is visible above the seal.

10

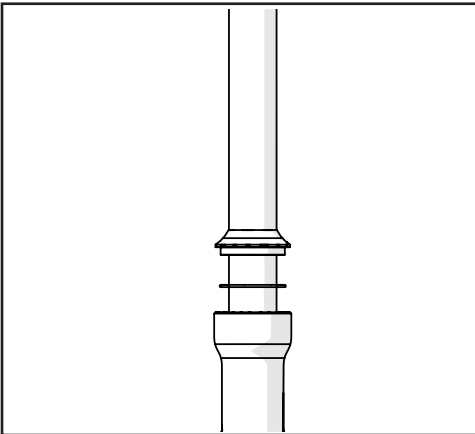

Grease seal before installing.

Install the C-Clip making sure it is seated correctly in the groove. Install the dust seal.

11

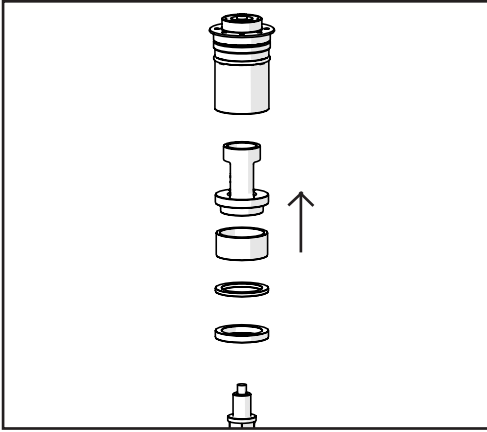

Remove the Top cap from the piston rod along with the nylon pusher, two preload spacers and the spring seat washer. To remove top cap use 14mm spanner to hold the rod and a 14mm socket on the centre of the top cap.

12

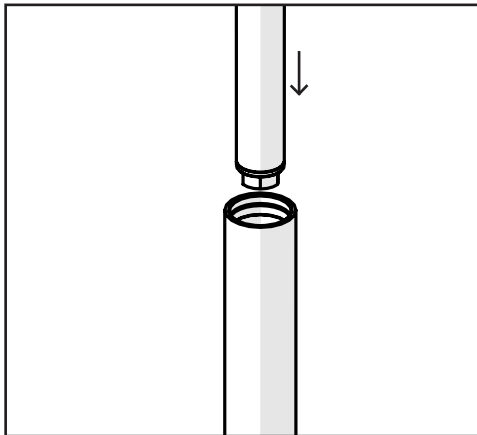

Install the cartridge into the fork leg.

13

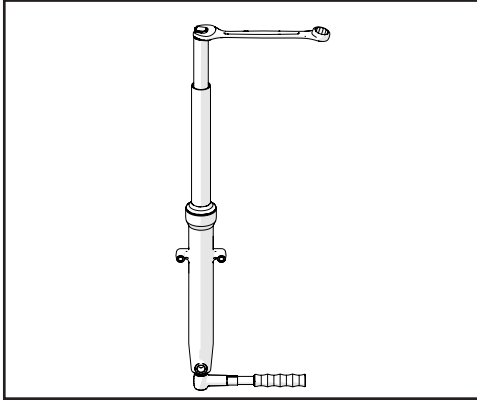

Screw the standard bolt into the base valve through the bottom of the base valve. Torque bolt to 35Nm using a 6mm hex, whilst holding the cartridge with tool no. 113-125-050 and a 24mm spanner.

14

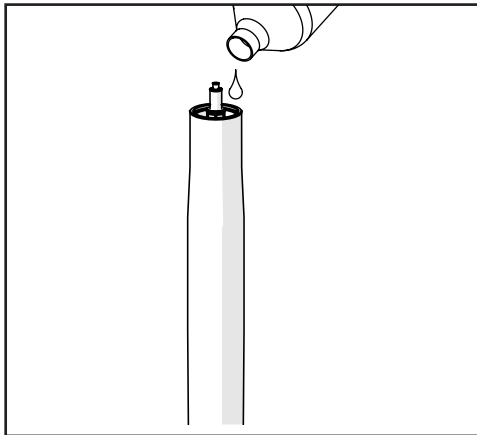

Pour oil into the fork to cover the top of the damper tube assembly.

K-Tech recommend 5wt.

15

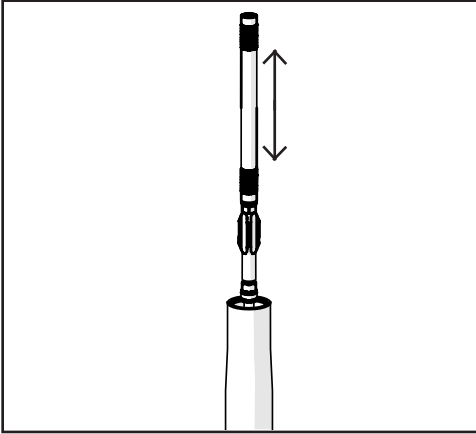

Make sure the oil always covers the top of the damper tube assembly.



There will be much more resistance when bleeding the compression leg (Left) due to the design of the system.

Pump the piston rod up and down using tool No. 113-030-005. Pump the rod up and down approximately 20 times until it feels smooth with no air bubbles in the oil.

16

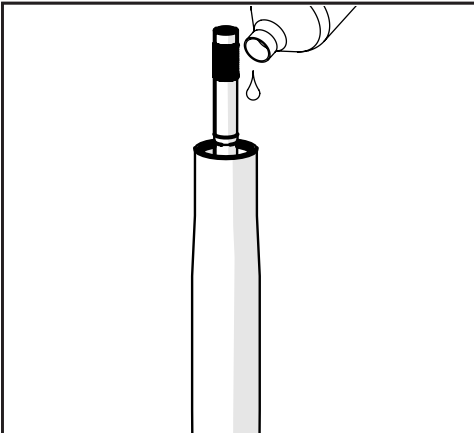

Completely fill the fork leg with oil.

17

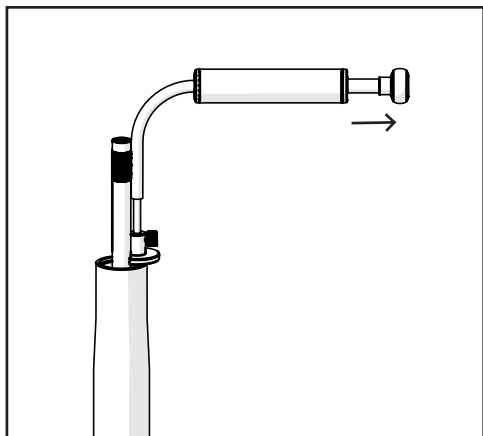

When setting oil level make sure the piston rod is fully down.

Set your oil level using tool No. 113-030-500. Set your tool to 160mm and suck the excess oil out.

18

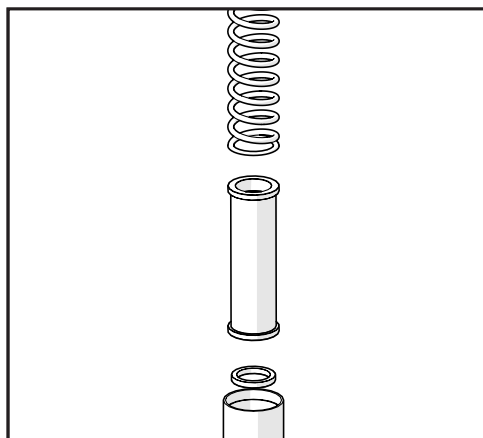

It is advised to use K-Tech springs as these are a smaller diameter and give a smoother action to the fork.

Install the spring seat washer making sure it seats correctly on the seal head assembly. Install the preload Spacer along with the spring you have chosen to use.

19

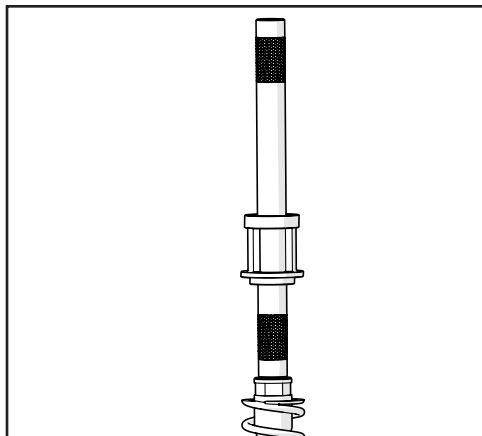

Pull the piston rod up using tool no.113-030-005 and install the nylon preload pusher.

20

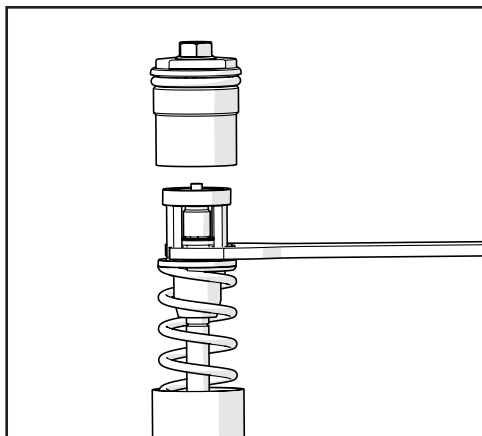

Holding the piston rod up with tool no. 113-030-005 place tool no. 113-010-020 onto the rod joiner and hold in place. Remove the pull up rod and install top cap.

21

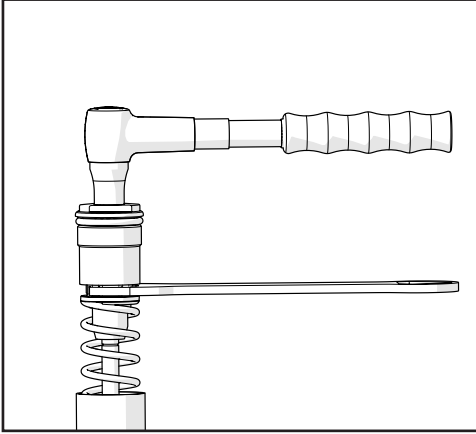

Torque the top cap onto the rod using a 14mm spanner and a 14mm socket, Torque to 12Nm.

22

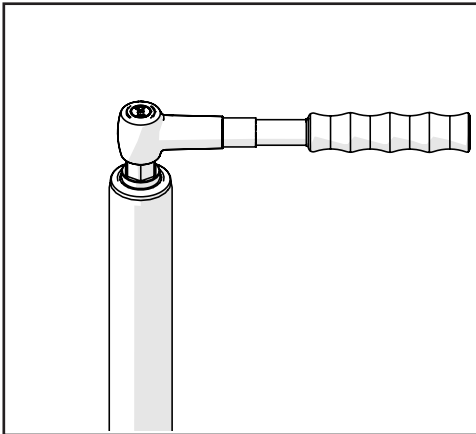

Screw the top cap onto the outer tube and torque to 10Nm using tool no. 113-010-115.



Grease O-Ring before installing.

23

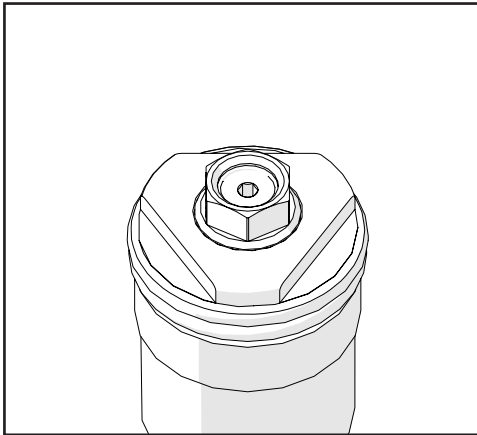

Set your compression and rebound adjusters using a 3mm allen key in the centre of the top cap. Adjust your preload using a 14mm spanner on the centre of the top cap. Make reference to the setting data in this manual.

- 24** Reinstall the fork onto the motorcycle in accordance with the manufacturers workshop manual.

RECOMMENDED SETTINGS

Cartridge stroke	130mm
Cartridge length	745.00mm
Compression:	-16 clicks out
Rebound:	-16 clicks out
Air gap:	160mm
Spring rate:	35-340-XXX
Fork position:	Set to owners manual



www.ktechsuspension.com

Contact your local K-Tech dealer for more details at
www.ktechsuspension.com/service-centres-and-partners